



Cera Façade

Ceramic – coated panels

Cera Façade CERAMIC - COATED PANELS



CERA FAÇADE is external cladding with a difference

Distinctive style, premium protection

Cladding that's light on weight & heavy on benefits

Striking, original style that brings your walls to life combined with maintenance-free living and durability that lasts the distance.

Its ceramic-coated panels protect against the elements while supporting healthy, comfortable living. Like all Modinex products, CERA FAÇADE delivers top quality, design freedom and real value – along with surprisingly low maintenance for decades to come.

Total peace of mind

Because we're serious about quality, CERA FAÇADE is CodeMark Certified. This means it's fully National Construction Code compliant and rigorously tested every three years. Plus, CERA FAÇADE is backed by guarantee for total peace of mind.



Why choose CERA FAÇADE?

Manufactured and proven in Japan, CERA FAÇADE is a pre-finished, ceramic-coated exterior cladding system that's now used worldwide.



Bush Fire Resistance - BAL40

Suitable for use in applications where non combustible materials are specified by the Deemed to Satisfy Provisions of the 2019 BCA Vol 1, Clause C1.9 (e), See Factsheet for full details.



Low maintenance

Upfront, ongoing maintenance and longevity – CERA FAÇADE ticks all the boxes to provide great value now and into the future. Get the sought-after composite look – for less.



Lasting colour

No need for re-painting or rendering: the high-performance surface prevents absorption of UV rays to preserve its colour and “new” look for longer.



Self-cleaning

With a coating that uses rain to clean itself, you can relax knowing that house washing won't be necessary.



Cost effective

Enjoy savings in maintenance and energy consumption, plus a low environmental impact with a high percentage of recycled materials.



Fast, cost-effective installation

The CERA FAÇADE exterior sliding system has been specially designed for quick, easy installation – saving you time and money during construction.



Versatile style

CERA FAÇADE's colours and finishes help create fresh and original facades. Blended with other materials for an "on-trend" composite look, exteriors can be taken to a new level.



DIRECTONE WHITE



FIOTTO BEIGE



FIOTTO BLACK



FIOTTO WHITE



MAREE STONE WHITE



MODERN SLIT WHITE



SEPHIRO WOOD BLACK

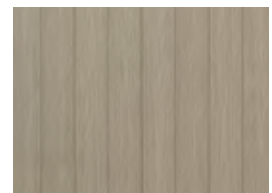

SEPHIRO WOOD GREY



SEPHIRO WOOD OAK

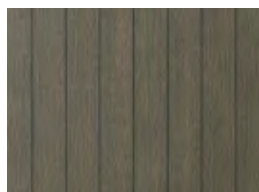

SEPHIRO WOOD SMOKE

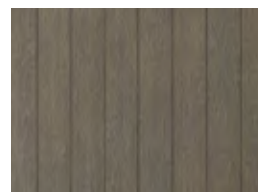

SEPHIRO WOOD WALNUT

How it works

Pre-finished panels, clever mounting clips and well-designed accessories provide a complete installation package for a faster, smoother build.

Ceramic coating: Lasting colour + low maintenance

CERA FAÇADE's ceramic coating resists fading and discoloration to sustain your home's style and quality for longer.

Testing shows that even over 30 years of exposure to the elements, colour loss is barely detectable.

Best of all, the coating can virtually maintain itself, using the natural environment to remove accumulated dirt.



Long-lasting colour



Self-cleaning



Low maintenance

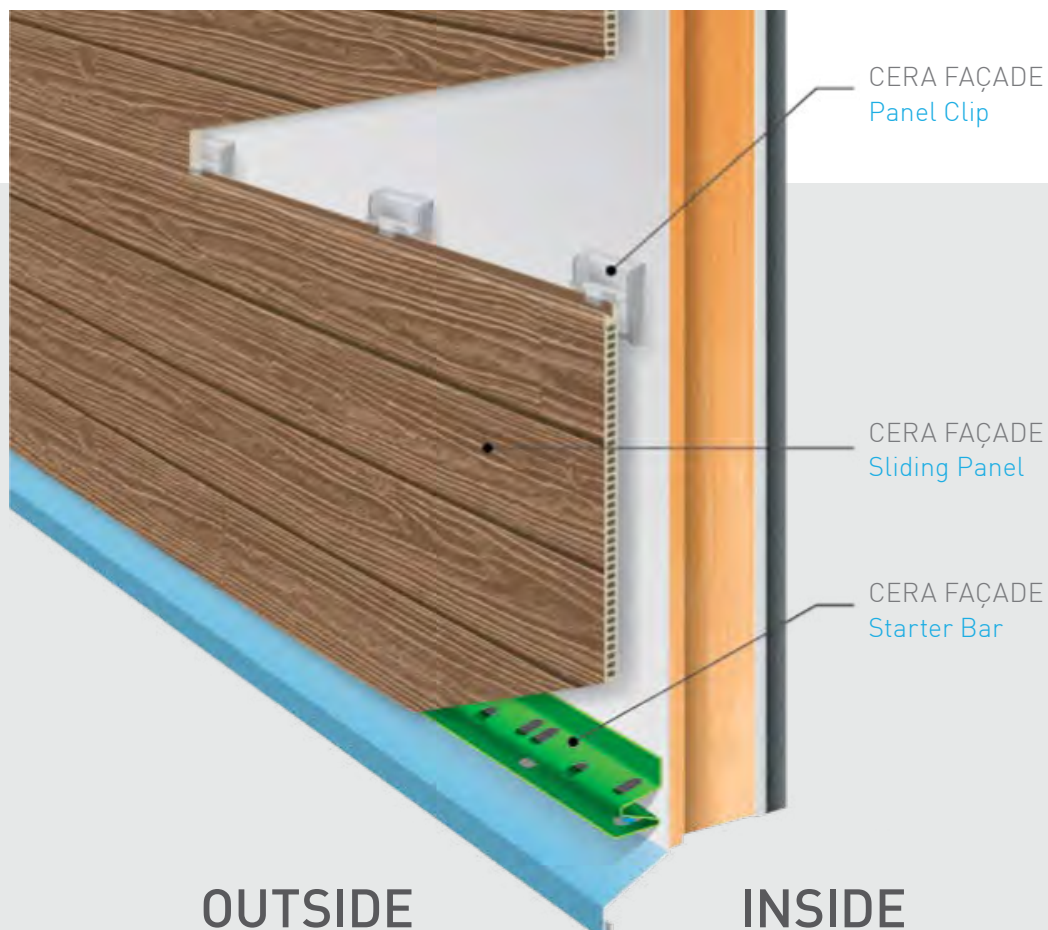



Ceramics explained

Modern-day ceramics are everywhere, made popular by their incredible durability, strength and thermal properties. From the everyday to the extraordinary, there is no doubting the proven performance of ceramics.

Uses include:

- Cookware and tableware
- Biomedical implants such as hip replacements
- Insulation for spark plugs and furnaces
- Space shuttle tiles, with future tiles expected to withstand temperatures of 2400°C



How it works

Self-cleans with rain

Forget hiring a house washer let the rain do the job and enjoy low-maintenance living.

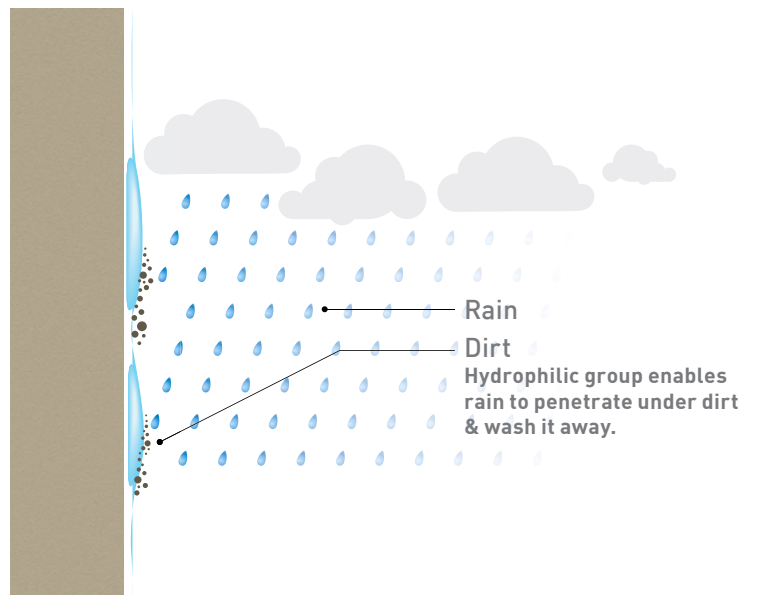

The Weather Test

A weather resistance test shows the superiority of ceramic coating. When subjected to continuous cycles of UV rays and water exposure over the equivalent of 30 years, colour loss is barely detectable to the human eye.

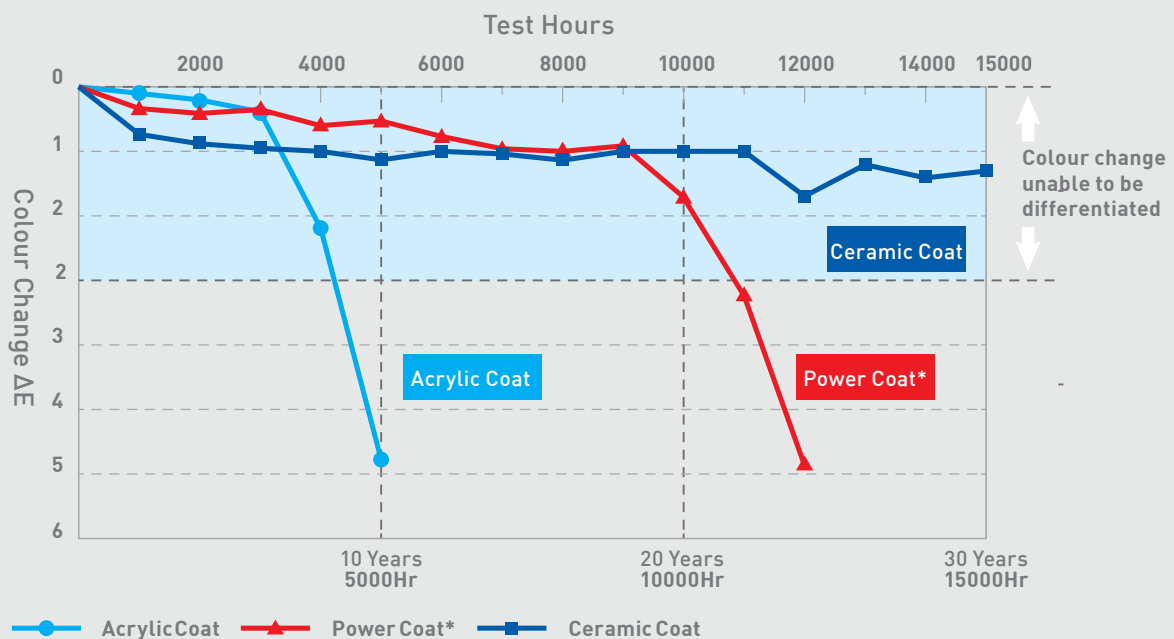

Test conditions are near to real conditions (CERA FAÇADE internal test)
 The horizontal axis of the graph indicates the irradiation time, and the vertical axis indicates the degree of colour fading. A colour loss of Delta E2 is barely detectable by the trained human eye. A colour loss of Delta E3 is noticeable to the untrained eye. As shown in the graph, Ceramic coated panels over a thirty year life will not fade to a level Delta E3 which is detectable to the untrained eye.

* Power Coat is another CERA FAÇADE coating grade which is Acrylic Silicon clear paint.

How it works

Pre-finished panels, clever mounting clips and well-designed accessories provide a complete installation package for a faster, smoother build.

Engineered panel joint Straight forward installation

CERA FAÇADE consists of pre-finished sliding panels and innovative mounting clips and accessories to ensure easy installation. The option to install the panels in either direction provides greater design flexibility.

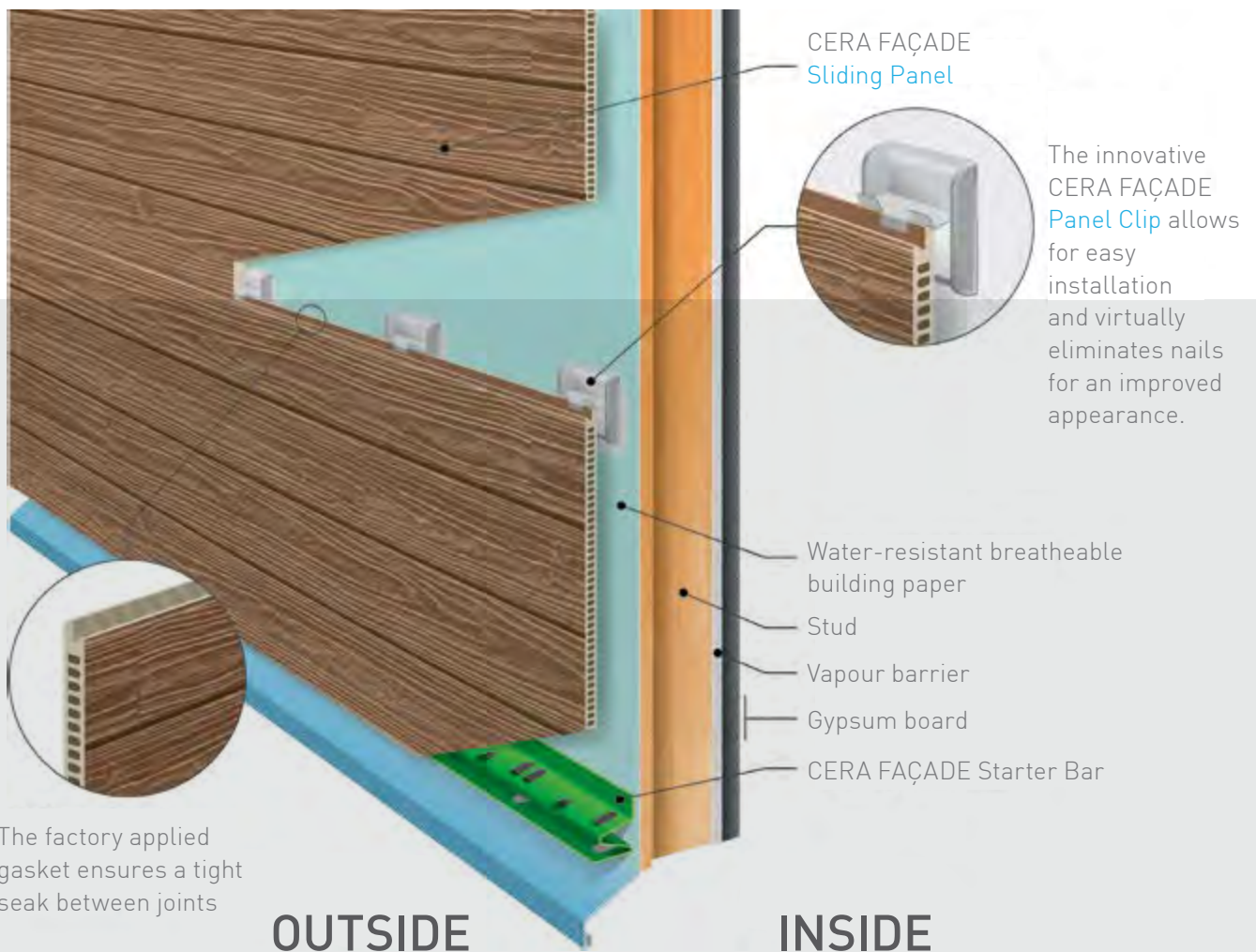

KMEW

CERA FAÇADE is a registered trademark in Australia and manufactured by KMEW. KMEW is a PANASONIC Electric Works Co. company.

Coating technology

The heat-resistant, UV-cutting ceramic coating maintains colour for many years.

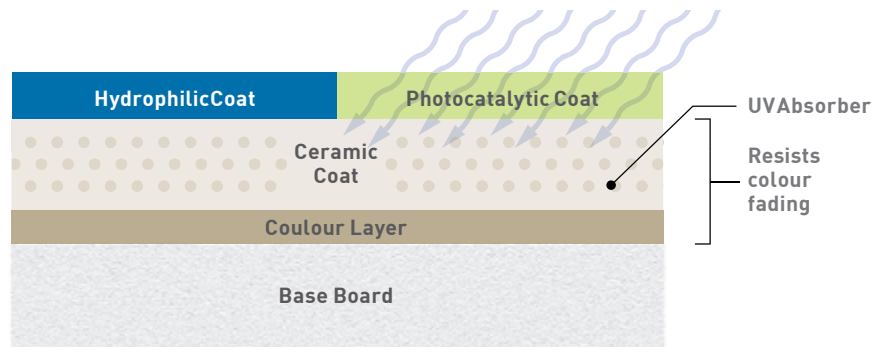

Ceramic coating molecule diagram

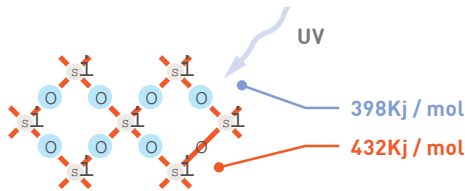

Molecular bonds are stronger than UV energy. Inorganic ceramic coat and UV absorption delays colour fading.

Installation

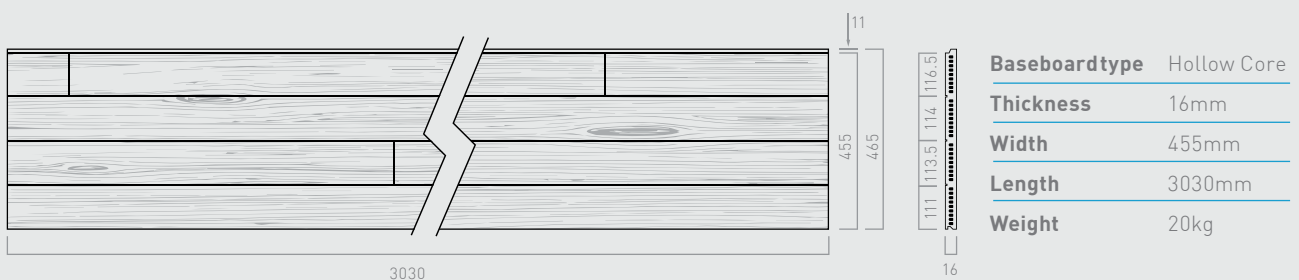

Panel Clip

Starter Bar

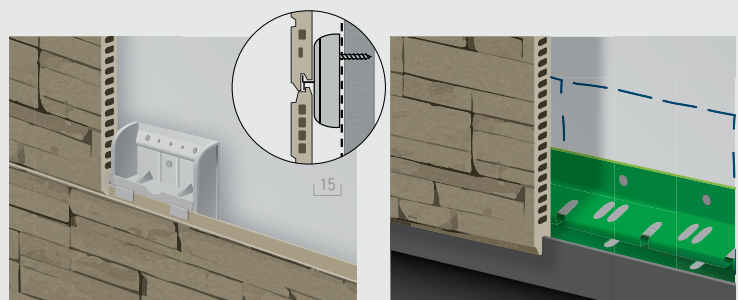
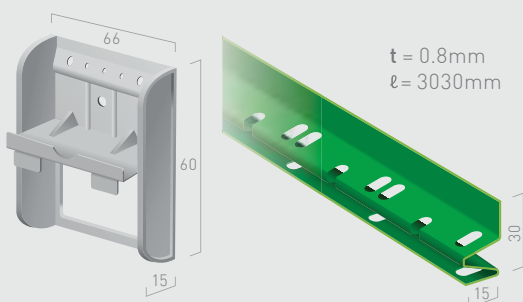

Further product information and downloads for Cera Façade are available at modinex.com.au



Installation Instructions



Product Care



CAD files



Technical Information



Visit Cera Façade page for more information



Like what you see?

Get in touch and order your free sample today!

Phone 1800 156 455 **Email** hello@modinex.com.au

For further product information and downloads **Visit** modinex.com.au

July 2022 Publication

modinexGROUP
LEADING EDGE ARCHITECTURAL