

## Points to consider for successful design

InStyle Decking is manufactured from solid hardwood and will behave and weather similar to standard hardwood decking. Timber decking is not a direct substitute for external tiles, pavers or composite decking and is suited to covered or sheltered areas for best performance. The beauty of the InStyle Decking however lies in its stylish appearance, its responsiveness and its unique feel under foot.

- Timber is like a sponge, which absorbs water to equalise its moisture content according to the ambient conditions to which it is exposed. As it gains or loses moisture content, it also expands and contracts.
- Consider the effects of the harsh Australian sun as it virtually cooks the timber at temperatures of 40°C+ day after day throughout summer. In these conditions, the tendency for decking boards to shrink at butt joints is hardly surprising.
- The life and appearance of the deck will be greatly extended by reducing exposure to the elements. Examples of this are: overhanging eaves, an awning, protection from adjoining buildings, shade sails, and ideally, a full roof structure.
- Likewise in exposure to prolonged damp conditions with low levels of evaporation, the boards will take up moisture and swell, especially at the end grain.
- The surface under the deck should be well drained to avoid a localised damp atmosphere, which can result in excessive swelling of timber.
- For more exposed applications it is better to use narrower board widths and certain species which have a slower rate of movement. Ask our sales staff for advice on the most suitable product for your application.

- InStyle Decking profiles have a concave bottom surface to minimise contact with the joist, which can trap moisture and rot.
- To avoid cutting the last board to final width, the overall dimensions of the deck should be adjusted according to the incremental sequence of the boards.
- Avoid installing decking over heat reflective surfaces (e.g. metal roof sheeting) in fully exposed applications.
- We recommend the timber be kept hydrated with Cutek coating to reduce splitting and movement, and to maintain more consistent moisture content. Modinex can also supply the decking pre-oiled all round so that the preservative can start penetrating prior to installation. A further two coats with colour tone are required once installation is completed, and maintenance coats should be applied at least once a year, or when the decking begins to dull.
- Consider adjoining surfaces. A beautiful effect can be achieved by building the deck at the same level as the internal flooring (check with your local building authority). Modinex can also supply internal flooring in matching timbers and similar widths to create an integrated flow through effect.
- For the best appearance, run the boards along the length of the deck with the butt joints staggered at random.
- Natural timber needs maintenance. Maintenance is required regardless of whether you want the rich pristine 'coated' timber look or the natural greyed off affect. Typically, horizontal exterior smooth surfaces exposed to full weather such as decking, may require recoating every 6 months to 2 years.

## Profile Selector

Scale 1:1

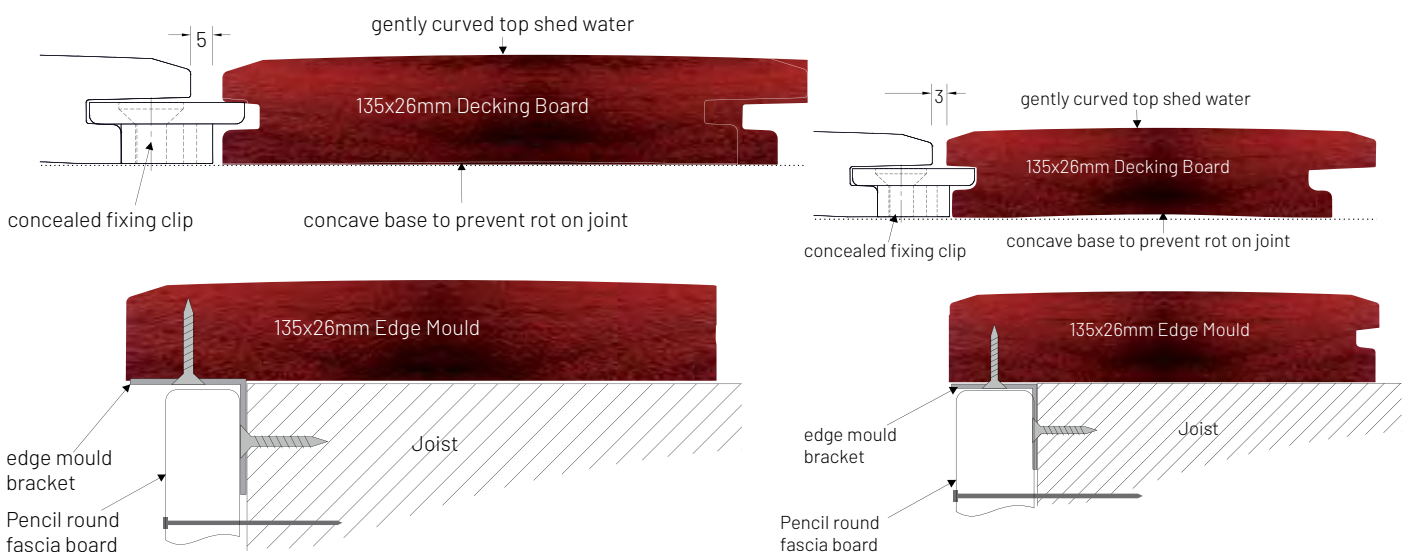

## Installation Instructions:

### STEP 1: Structural framing construction

- InStyle Decking can be installed on steel or timber structures.
- Modinex recommends the use of joist and bearer flashing on timber structures to reduce expansion and contraction and to minimize structural rot.
- End joists need to be constructed as illustrated where edge moulding is to be installed.
- Joist centres to be nominal 450 mm.

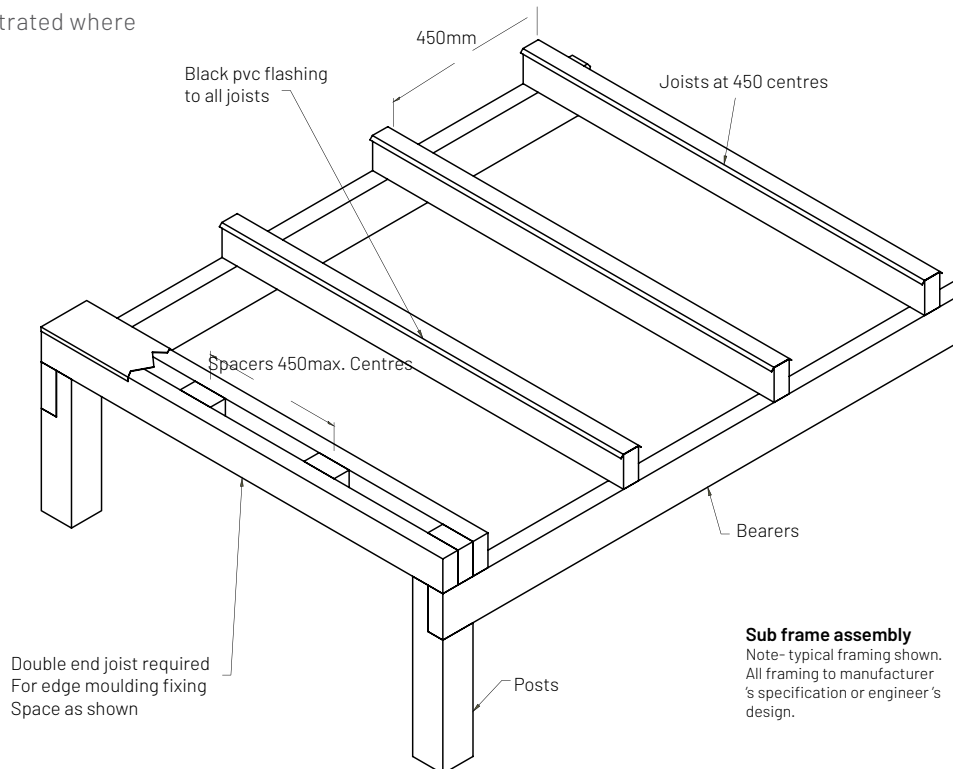

### Concealed Fixing Details

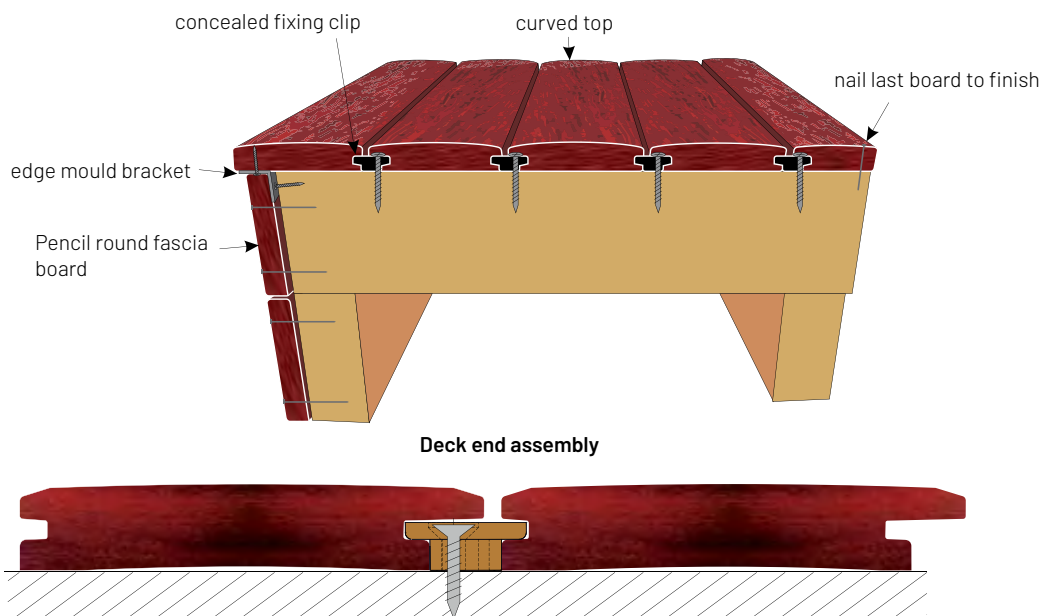

## STEP 2: Edge Moulding Installation

- Fixings to be at maximum 450 centres.
- Mark the fixing locations from structure onto the edge moulding prior to installing the angle bracket.
- Angle brackets are screwed to edge moulding using two 6# x 16 mm galvanised screws. Pre-drilling may be necessary. See Section A.
- Install the edge moulding onto the joists as illustrated, using a deck screw into the side of the joist. Section A & B
- To achieve a flush, neat mitre on the corners, a biscuit-joint is edge mould recommended.

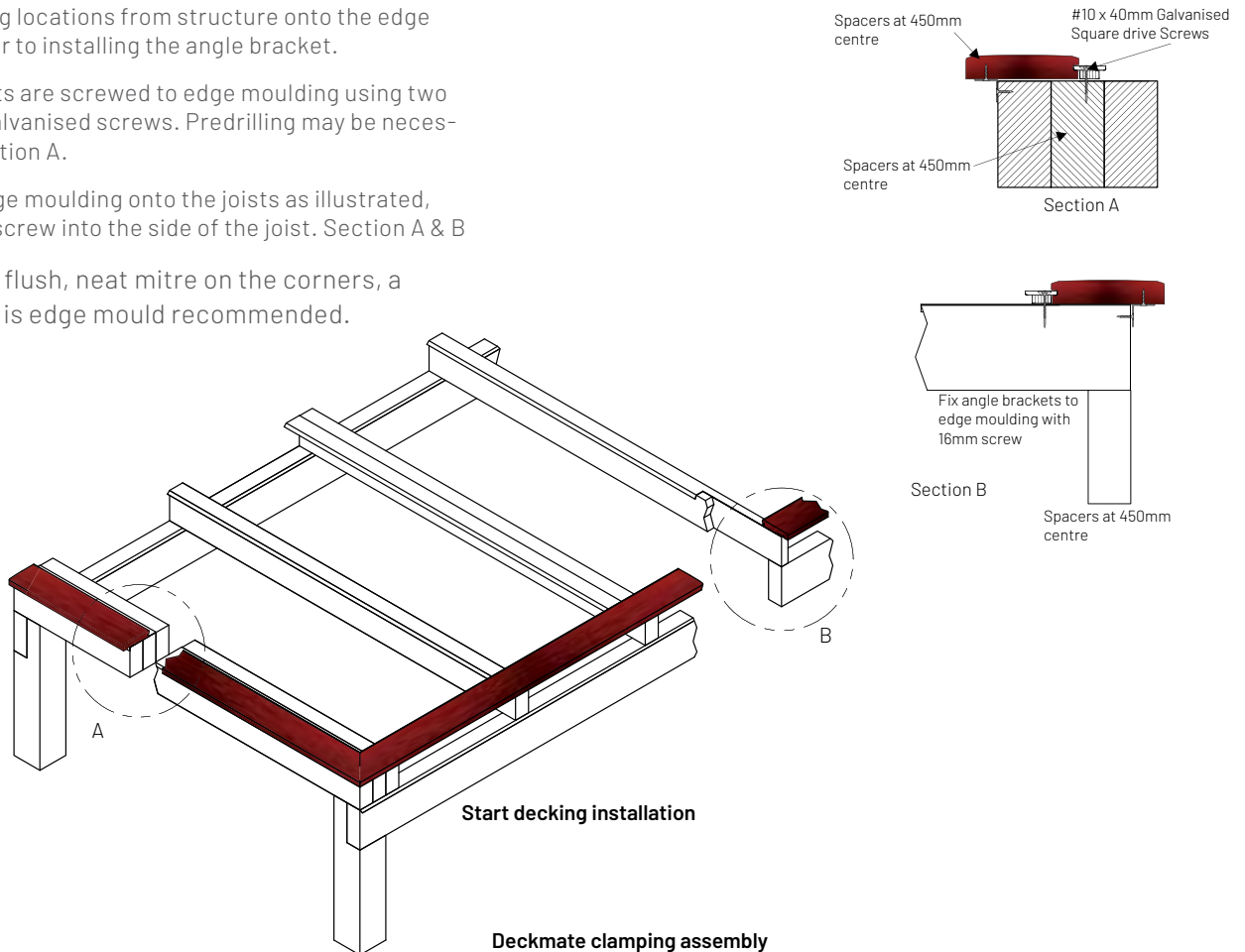

## Options

### Pre-oiling system



- Eliminates process of manually oiling each board all round prior to installation.
- Gives the penetrating oil a chance to soak in prior to handling the timber.
- The deeply penetrating oil working from front & back of the board improves dimensional stability.
- Requires a topcoat after installation.

### Deckmate clamping assembly

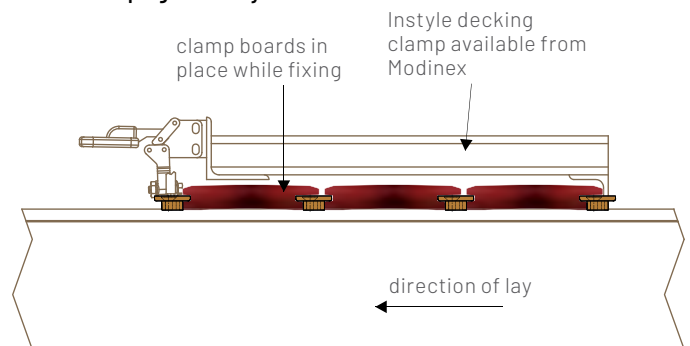

The precise nature of the InStyle Decking installation system requires the decking boards to be accurately positioned while screwing down the fixing clips. Timber boards by nature are not always perfectly straight and with durable hardwoods, considerable force is required to make them comply. The deckmate is a clamping jig which grips in a preceding board gap and pushes the front edge of the board being placed, firmly back against the previous row of clips. The clamping action is a toggle clamp which has a quick lever action and about 500kg of force.



## STEP 3: Installing the decking boards

- Pre-cutting and loose laying 10+ rows in advance is the most effective way of working. This allows you to oil the backs of the boards prior to laying and to see where butt joints are required in advance.
- The board laying sequence starts at the edge moulding and works back to the wall.
- Use a rubber faced mallet to engage the board with the preceding row of clips. Stand on the board as you tap it to stop it bouncing around. Use the Deckmate clamp to secure into place.
- Note, that most of the strength of the Deckmate side clamp is within the last few millimetres of its stroke. Adjust the plunger for maximum force.
- When screwing down the fixing clips, use a scrap piece of decking on the open side of the clip to act as a spacer, keeping it level. Angle the screw by 20° towards the preceding board. This pushes the clip firmly against the board as the countersunk head seats home and allows the next board to be easily tapped into place.

- Butt joints should be centred on the joist and secured with a clip on both sides to prevent end splitting (refer to illustration Detail B). To avoid end grain swelling on butt joints, leave a 1 mm gap to allow water to drain out and seal the end grain. Detail B
- For the best appearance stagger the butt joints apart and give the top surface a light sand to make sure the boards are flush.
- For decking boards that run at a right angle to the edge moulding the end clip must also slot into the edge mould.
- When laying over a large area, take some measurements to check that the boards are keeping parallel to the edge moulding.
- Use a 3 mm spacer to maintain a consistent gap between the end of the decking boards and the perpendicular edge moulding.

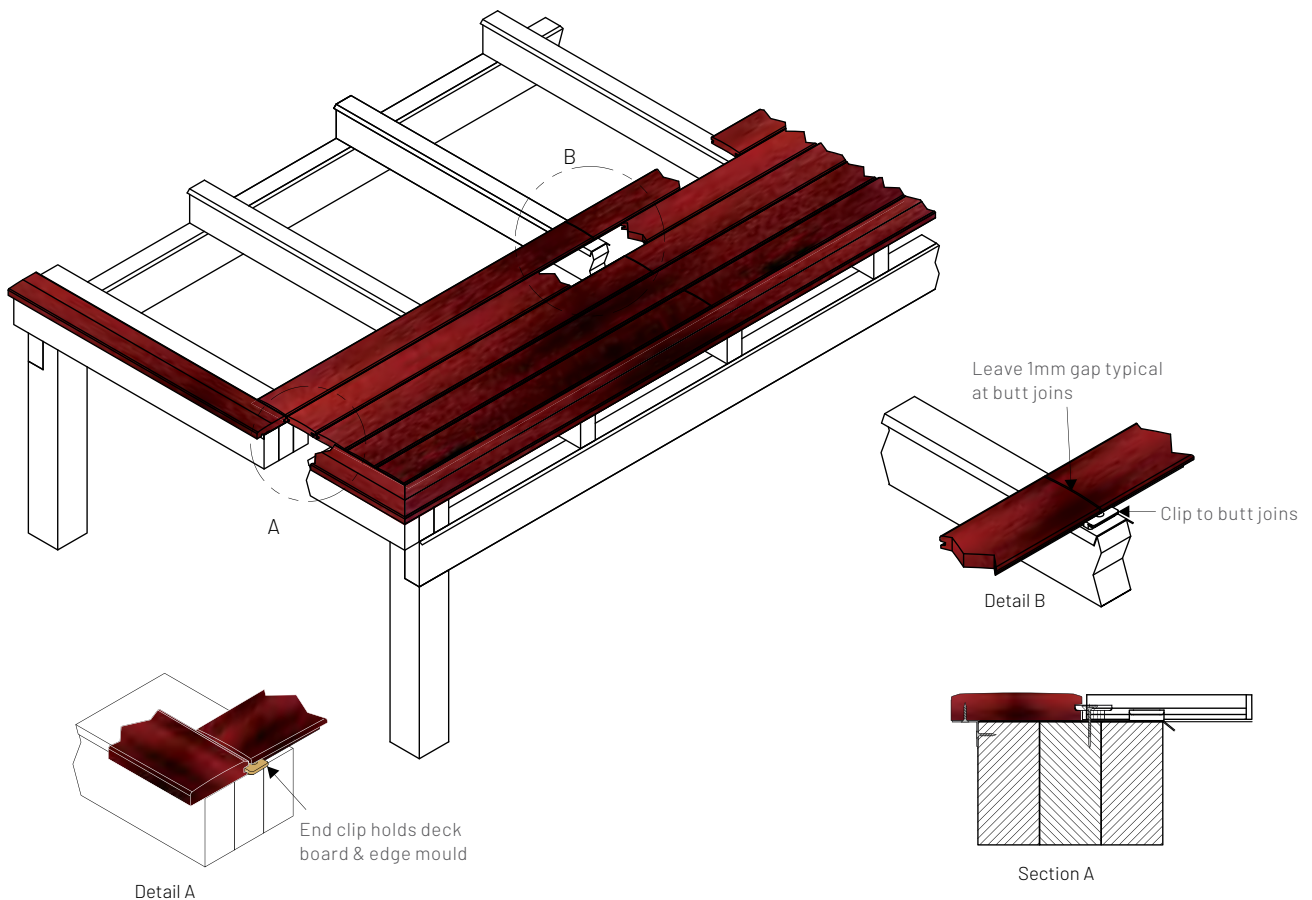

## STEP 4: Final Touches

- The last board may need cutting to final width as illustrated. It will either need to be neatly face fixed or screwed and plugged. Section B.
- Decking boards on the vertical face are laid in the same manner as conventional decking, starting from the edge moulding and working down. Section C.

## Decking on Waterproof Membranes:

Decking is laid over waterproof substrates like a floating floor. The decking boards fastened to the cross-battens form a self-contained ladder frame unit which floats on the waterproof substrate. Note the following:

1. Where the surface drains to a gutter on one side, the cross battens must run in the direction of fall.
2. Where the surface drains to a central point, packers maybe used under the cross battens to maintain the deck level.

3. Make sure the cross battens are free of all burrs which can penetrate the waterproof membrane.
4. The cross battens can be of aluminium, Class 1 hardwood or similar durable material.
5. To prevent the decking frame creeping out of position, it should be secured to another structural member at a minimum of two points.
6. Wind lift is a consideration in some applications, requiring the deck frame to be suitably anchored.

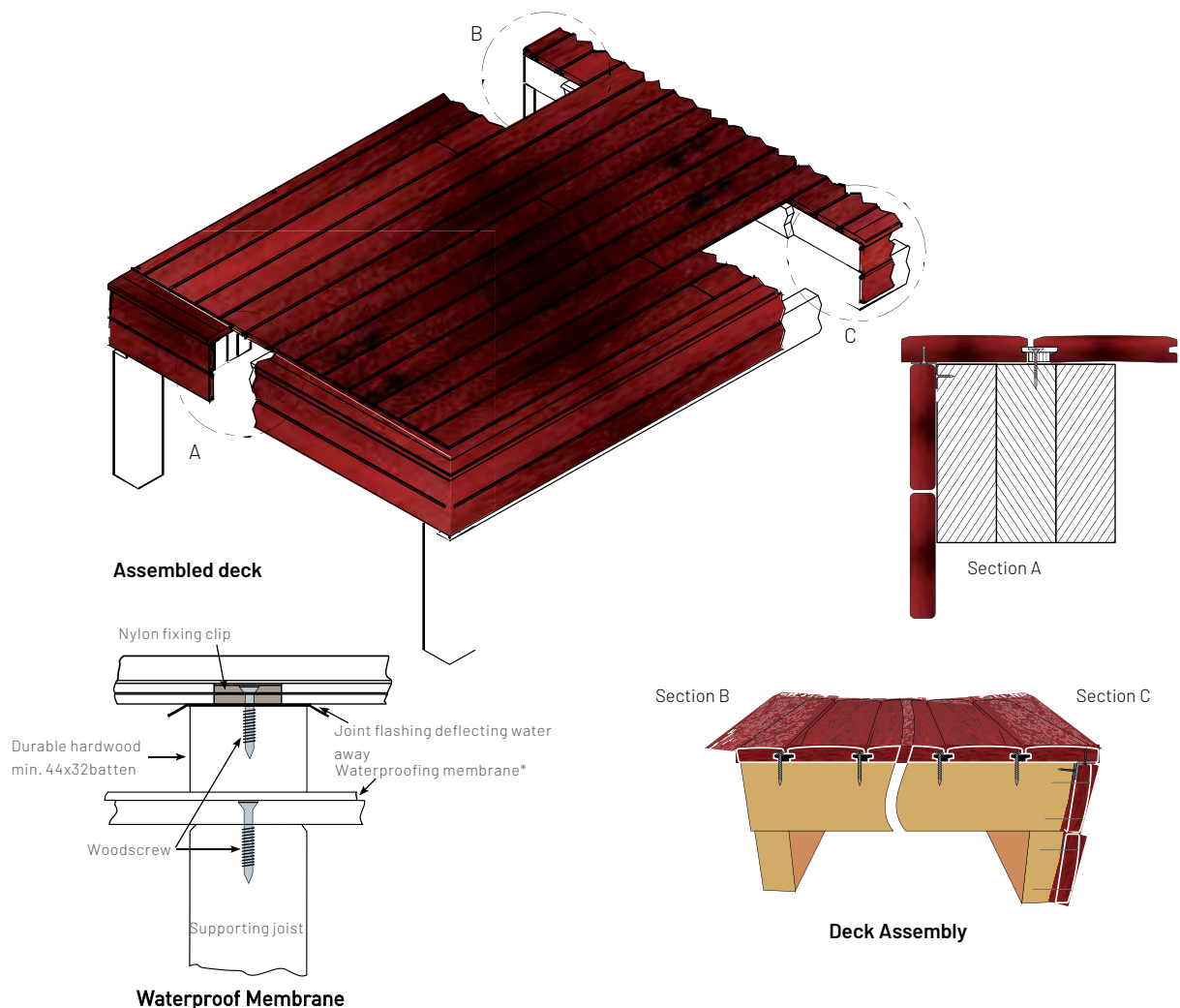

## Product Care / Design Specification / Delivery:

### Allowing for movement

Understanding & allowing for expansion & contraction in timber.

### Timber moves

This is an unchangeable fact. If the potential for movement in any given application is considered, calculated and allowed for in the design and installation stages, the majority of problems can be avoided. If timber moves in installation it is always a reaction to change of circumstance and cannot be considered defective unless proven to be outside the specified moisture content range at time of delivery. By far the most movement occurs across the width of a back sawn board.

### How does movement occur?

Timber expands and contracts in width in direct proportion with increase or decrease in moisture content. Timber is a hygroscopic material which means it releases or absorbs moisture to equalize with the air/medium it is in contact with. The amount of moisture in the air is a relationship between temperature and relative humidity. Therefore we can say that timber expands and contracts in width in response to ambient changes in temperature and humidity. As a guide, a Spotted Gum 88 x 20 mm decking board will move by approximately 0.4 mm in width per moisture content percentage change.

### How to predict and allow for the range of movement

It is necessary to predict, as far as possible, the range of movement to be expected in a given application. This can then be allowed for by: leaving room for expansion between the boards, expansion joints if necessary, choosing suitable species or changing the width of a board. The following factors influence movement: Tangential shrinkage rate of the species (rate of shrinkage across the width of a back sawn board).

- Annual cycle of weather – available from BOM website.
- Level of exposure to sun/weather i.e. Direction, overhanging eaves, shadows etc.
- Size of the area to be decked.
- Waterproofing and water runoff.
- Weather protection in construction.

The standard profile design allows 3 mm expansion and 5 mm contraction which is sufficient for normal conditions. The important thing is to identify the

possibility of excessive conditions and make sure these are provided for. Modinex offer the service, on request, of calculating the maximum moisture content and hence the expansion and contraction in an area based on the information provided by the Bureau of Meteorology and the tangential shrinkage factor. Don't hesitate to discuss with us any concerns you may have on your project. Note: Modinex can only offer advice and cannot accept liability for onsite reactions.

### Design specification

To assist in achieving your desired result, the following information should be drafted into your project specifications to ensure that inferior products are not used on your project.

All timber decking surfaces to be Instyle Decking, with concealed fixings, supplied according to the following specification and installed in accordance with the Building Codes of Australia and the manufacturer's installation guidelines.

### Example of how to set out specification:

**Product Name:** Instyle Decking

**Legend:** ISD

**Timber Species:** (Ironbark, Spotted Gum or Blackbutt)  
Others available on request

**Grade:** Natural Select (min 2/3 select, max 1/3 standard)  
(Select Grade available on request)

**Moisture Content:** 10-14%

**Fixing:** Nylon Concealed fixing clips with square drive, Self-drilling screws supplied by Modinex.

**Finishing:** Pre-oiled with 1 coat of Cutek Wood

Preservative clear, additional top coats with colour tone Onsite (after installation by others)

### Note:

- Timber joists to be covered with joist flashing
- All exposed edges to be finished with proprietary Instyle edge moulding
- All end grains to be properly sealed with Cutek Wood Preservative
- Timber must be acclimatised prior to installation
- Adhere to expansion and contraction requirements
- Contact Modinex regarding any special requirements or queries



### Product Supply Specification:

Modinex, as the manufacturer of Instyle decking, supply according to the following specifications:

### Profile Accuracy:

Machining tolerance measured at time of manufacturer is +/- 0.2 mm in dimension and profile. Due to variance in timber moisture and characteristics, boards may swell or contract individually when exposed to the elements.

### Surface finish:

Furniture grade smoothness, ready for oiling – top surface only. Minimal chipping may occur with interlocking grain.

### Moisture Content:

Within a range of 10-14% M/C

### Straightness:

Max warp/bow – 7 mm per metre.

### Grade:

Natural Select (min 2/3 Select, max 1/3 Standard according to AS 2796.2) Minimal surface checking allowed. Graded top face only.

### Length:

All timber is supplied in random length, ranging from 0.9m to 6.0m, unless otherwise specified. Average length = +/- 2.7m. Max of 15% under 1.8m.

### Colour Selection:

Colour selection is not part of the grading process except with extreme variations according to the discretion of Modinex. Colours can vary significantly from rich browns to greys. This is a natural characteristic of timber.

### Species Selection:

All timber selected according to species classification as covered in known trade names, i.e; Spotted Gum, Ironbark. Other species are available upon request.

### Durability Rating:

Above ground Class 1 or 2 (AS 5604).

### Specification Variance:

Up to 5% of volume.

### Pre-Oiling with Cutek Option

This option provides the application of 1 clear coat of Cutek coating to all 4 sides of each board. Further applications are required after installation to maintain the appearance of the timber – refer to timber finishes section.

## Order and delivery procedure

### Quotation & Order Process

InStyle Decking is manufactured and distributed throughout Australia by Modinex. We offer a free estimation and quotation service from your plans. This has the advantage of giving you an all-inclusive up-front costing for your job based on the information you provide us at the time of quoting. We look at any special requirements you may have and resolve these with you to ensure that you have all the materials you need to complete the job. You can go through the quotation with us to ensure we have interpreted your plans correctly. Simply sign off your quotation acceptance at the bottom of the quote and indicate your preferred delivery date. On receipt of your quotation acceptance we will contact you to put the necessary arrangements in place to ensure a timely delivery in a satisfactory manner.

### Taking Delivery

Smaller orders are normally hand off-loaded. It is necessary for you to provide sufficient labour to complete this task in a reasonable timeframe. Modinex can arrange a crane truck delivery for larger orders on request. This is an efficient way of off-loading, but does cost extra.

The following steps should be taken when accepting delivery:

- Get the delivery document from the driver and check that you have the correct quantity of packs.
- Assess the overall condition of the pack on the truck – any damage should be notified on the signed delivery document which is given to the driver, and Modinex should be informed immediately.
- Find the packing slip which is placed in a clear sleeve on the top of the pack.
- Cut the shrink wrap and steel strapping (if hand unloading).



- Check off all items against the packing slips, particularly any accessories ordered. Total linear metre can be estimated/ checked by multiplying the average length by number of pieces.
- Notify Modinex if any inconsistencies.
- Any claim must be made within 7 days of delivery.

## On-Site Storage & Acclimatisation

- All timber should be stored undercover, on bearers at least 50 mm above ground and with plenty of airflow.
- Timber that is not neatly stacked is much more likely to twist or warp.
- At least two weeks acclimatisation period is necessary in areas of extreme weather conditions to avoid excessive expansion and contraction after installation.
- The decking boards could be coated at this stage if the timber has not been supplied preoiled.

## Surface finishes

External decking is one of the harshest applications for timber surface finishes due to the destructive UV rays of the hot Australian sun. As a result, ease of maintenance is a prime consideration. We recommend a good quality Cutek oil which is very easily applied using a lamb's wool applicator.

## Advantages of oils:

- Brings out the natural beauty and character of the timber.
- Penetrates and feeds the timber, providing dimensional stability.
- Allows the timber to breathe.
- Tends to disappear and thin out when breaking down without blistering and peeling.
- Can be quickly reapplied by an unskilled person using a lamb's wool applicator.

## Benefits of Cutek Coatings

Cutek Coatings is a specially formulated oil timber preservative for interior and exterior use, which is designed to penetrate deeply into hardwoods, providing resistance against surface decay, fungus and mould,

in addition to providing water repellency, and assisting with dimensional stability. Cutek does not peel off or crack, but helps to control warping, cupping and splitting, effectively enhancing the service life of the timber. This characteristic ensures that future recoat preparation consists of a simple wash-down of the timber with SARA Clean, rather than conventional sanding or stripping, resulting in significant savings in ongoing maintenance costs and time. Cutek is suitable for use as a clear, water repellent preservative coating on exterior timber surfaces. However, the clear coated timber surface will silver with age to produce a natural weatherboard appearance, while retaining its dimensional stability and bio-toxicity characteristics. If this natural silvering of the timber is undesirable, then Cutek is also available in specially formulated colour tones that will maintain and enhance the natural character and colour of freshly oiled timber.

## Division of Responsibility:

1. Modinex is responsible to:
  - a. Provide specifiers and installers with product information
  - b. Manufacturer and supply according to the product specification
  - c. Develop products which provide long-term durability and satisfaction
2. Specifiers are responsible to:
  - a. Determine the suitability of the product for each specific application, taking into account localised demand and exposure factors
  - b. Educate the client as to the product characteristics and required maintenance
3. Installers are responsible to:
  - a. Comply with the building code of Australia
  - b. Install the product to the manufacturer's and specifiers' specification
4. Owners are responsible to:
  - a. Understand that timber is a natural product with its own natural characteristics eg. Colour variation, expansion and contraction etc.
  - b. Maintain their masterpiece

